



Owner's Manual

Operation and Maintenance Instructions

Wisper 905se Sport and City S

January 2010 1st edition

Revised August 2010

We strongly recommend that you read this entire manual before
using your Wisper bike

Wisper Limited



User Guide

Introduction Page 3

Part 1 Caring for your Wisper bike and pre use checks

1	Before you set off for the first time	Page 4
2	Before each use	Page 5
3	Battery care	Page 5
4	Recharging your battery	Page 6
5	Water	Page 6
6	Maintenance and adjustments	Page 6
7	Technical specifications and performance	Page 8
8	Simple trouble shooting	Page 8

Part 2 Controls and Equipment

9	Battery on off and battery lock	Page 9
10	The ON/OFF button	Page 10
11	The LIGHT button	Page 10
12	Pedelec mode and ASSIST button	Page 11
13	Throttle	Page 11
14	Brakes	Page 11
15	Steering stem and handle bar clamp	Page 14
16	The front connection box	Page 15
17	Quick release saddle height adjustment	Page 15
18	Saddle post suspension	Page 15
19	Rims and spokes	Page 15
20	Chain and drive wheel	Page 16
21	Derailleur	Page 16

Warranty Page 17

Service contacts Page 17



Introduction

Thank you for choosing a Wisper electric bicycle.

By making the decision to use an electric bike you are helping to safeguard our environment by saving our planet's precious resources and reducing carbon pollution.

Before you use your Wisper bike it is important that you read this manual carefully. If there is anything you do not understand completely please contact us.

Please observe traffic regulations, and don't lend your bicycle to anyone who is unfamiliar with it. The bicycle can only legally be used on the road by a person aged 14 years or older.

We strongly advise you to always wear a cycle helmet when using your bicycle and if you are unfamiliar with cycling to attend a cycle proficiency course prior to using it. Your Wisper Works 905se range is not a toy and should be considered a serious mode of transport.

As with all bicycles it is important that you stay within safe limits, if you feel as if you are traveling too quickly for the road conditions you probably are so slow down.

Test your brakes prior to using the bike every time you use it and remember the bike will not stop as quickly in wet or icy conditions as it would on a dry road.

Before you use the bike for the first time you must make absolutely certain that it has been correctly assembled. You can do this by either taking it to your nearest cycle engineer or if you are proficient in cycle mechanics inspecting it yourself. In particular you must make sure that the pedals, saddle, handle bars and any self assembled items have been correctly fitted.

NEVER drink alcohol and ride your electric bike. The use of alcohol greatly reduces reflexes and limits your ability to ride safely. Even a very small amount of alcohol will limit your ability to be safe on the road.

Always wear an approved cycle helmet.

When you need to replace your battery please either dispose of it properly or preferably send it back to us or our distributors and we will make sure it is properly recycled.

Happy cycling!

Wisper Ltd



Part 1 Caring for your Wisper bike and checks

Although your Wisper bike has been thoroughly tested prior to delivery, it is very important that you check the bike thoroughly before its first use. Equally important are frequent and regular spot checks they will protect you and your Wisper bike.

Please read this manual carefully. Only on full understanding of all the functions of this electric bicycle should you attempt to use it.

Your Wisper bike has been transported in a strong seven-layered corrugated carton. To save space it has been delivered with the front wheel, handlebars, seat post and seat, rear rack and pedals ready for assembly with the tool kit provided.

- * Rack not supplied on 905se sport model
- ** Your retailer may have assembled your bike for you if not you will find fitting instructions on the Wisper website www.wisperbikes.com

1 Before you set off for the first time

- 1.1 Check the handle bars and handle bar stem are properly tightened
- 1.2 Check all other nuts and bolts and fixings are properly tightened, pay particular attention to the motor fixings, side kick stand, yoke and steering head bearings
- 1.3 Check brakes and brake isolators are functioning properly
- 1.4 Check tyre pressures are correct and tyres are not damaged
- 1.5 Check reflectors and lights if fitted are functioning properly
- 1.6 Make sure battery is fully charged
- 1.7 Load battery into bicycle and turn on with key
- 1.8 Check the **power indicator lamps** are illuminated on the left hand side of the handle bars if they do not illuminate press the **on / off** switch once

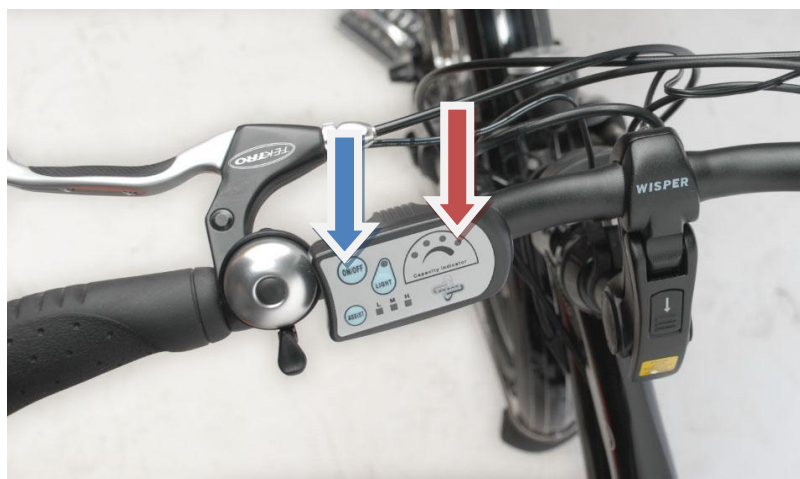



- 1.9 To avoid dangerous unplanned acceleration, always make sure that the electrical system is turned off and the **power indicator lamps** are not illuminated when mounting, dismounting or leaving the bike unattended. For your safety, please turn off the power key on the battery when stopped or walking the bike
- 1.10 Remember to validate your warranty by visiting www.wisperbikes.com/mywarranty and filling in your details.

2 Before each use

It is important you perform a quick check of your bike every time you use it. Checks should include the following (if you do find any damage or problems do not use the bike until the problem has been solved or you have had the faulty item checked by a bike mechanic or your retailer).

- 2.1 Check tyres for any visible damage
- 2.2 Check tyre pressures
- 2.3 Check for any loose nuts bolts or fixings
- 2.4 Check brake functions
- 2.5 Check electronic functions
- 2.6 Check reflectors are in place and lights are working
- 2.7 Check your battery for any visible signs of damage

3 Battery care

- 3.1 Before you use the battery for the first time it is best to give it a full deep charge for 12 hours. To fully condition your new battery give it complete deep charge, discharge cycles for the first three charges. This is achieved by charging your battery for 12 hours and then using the bike until the battery is completely drained. After this “conditioning” process you can then charge and discharge the battery as and when you require for long or short periods.
- 3.2 If you are going to leave your battery uncharged for more than eight weeks it is best left half charged. You should then re charge it every four weeks for two hours to keep it in top condition.
- 3.3 Before setting off on any journey it is always better to have a fully charged battery
- 3.4 Always remember that you use up to three times more power when setting off under the twist throttle. To preserve the life of each charge always set off using pedal assist
- 3.5 Do not expose the bicycle or battery pack to fire, heat sources, acid or alkaline substances

- 3.6 When leaving your bicycle during hot weather always leave in a shaded well ventilated area
- 3.7 For best results always recharge the battery at room temperature
- 3.8 Before unloading the battery make sure it is turned off at the key, then raise the saddle and unload the battery using its handle
- 3.9 If your battery is damaged or appears to be overheating for any reason immediately return it to your retailer for advice and a safety check

4 Recharging your battery

- 4.1 Make sure the charger is turned off and connect the charger to your battery then turn on the charger. Red and yellow lamps on the charger indicate the battery is charging, when the yellow light turns green the battery is fully charged. Always turn off the charger and disconnect from the mains after charging. Always disconnect the charger from the mains before disconnecting the charger from the battery. It is possible that the battery will take up to 12 hours to charge on the first three charges.
- 4.2 When charging the battery always do so in a well ventilated area.
- 4.3 Do not leave the charger connected to the mains when not in use.

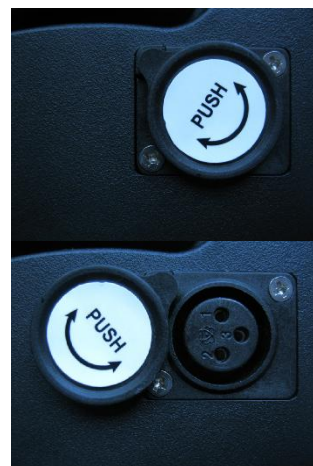

5 Water

- 5.1 Your electric bicycle is rain and splash proof and can be used in all weathers.
- 5.2 The electrical components of the vehicle, such as motor, battery, and controller, must not be submerged in water.

6 Maintenance and adjustments

- 6.1 **IMPORTANT!** Do not attempt to open the casings of the battery, motor or controller it could be dangerous and all warranties will become void. If you experience a problem contact our service department or your retailer.
- 6.2 Wheel spokes should be adjusted after 300 miles riding. Handlebar and saddle tubes should never be raised beyond the maximum indicated by a safety line around the tubes. The recommended torque on the nuts is as follows:
 - (A)Front axle nuts. 46N.M
 - (B)Back axle nuts. 70N.M
 - (C)Handlebar clamp bolts. Bolt 1:16N.M, bolt 2:10N.M (Refer 15.1 picture)



(D) Handlebar stem expander bolt.	(18 to 20)N.M
(E) Seat pillar clamp nut/bolt.	(5-8) N.M
(F) Brake cable anchor bolt.	5N.M
(G) Brake centre bolt.	11N.M
(H) Seat clamp nuts.	24N.M
(I) Crank axle nuts.	R:42N.M L: 46N.M
(K) Gear shifter nuts.	4N.M
(L) V brake caliper nuts.	10N.M
(M) Rear carrier nuts.	8N.M
(N) Mudguard bracket nuts.	8N.M

Other nuts torque depends on the nuts volume. M4 :2.5-4.0N.M M5 :4.0-6.0N.M

M6 : 6.0-7.5N.M

- 6.3 Your bike has a rear derailleur that will automatically tension your chain. However if the chain becomes loose or frequently comes off the front cog, please seek advice from your nearest Wisper dealer.
- 6.4 The brake levers should lock the wheels when compressed half way between their open position and touching the handle bars. If not please adjust following instructions provided below.
- 6.5 Warning: Handlebar hand grips or tube end plugs should be replaced if damaged, as bare tube ends have been known to cause injury.
- 6.6 Warning: Any replacement forks must have the same rake and same tube inner diameter as the originally fitted to the bicycle.
- 6.7 Disc brake pad wear and replacement. Remove the brake pads and check them for wear. If the friction material is less than 1mm thick then they need to be replaced. Rear brake blocks must be replaced if the grooves are no longer visible.

IMPORTANT braking distances increase on wet or icy roads.

- 6.8 Lubrication:
- 6.8.1. Once a month lubricate all pivot points on the derailleur with chain lube and apply a light oil to the upper fork leg where the lower leg slides on it. Wipe clean.
- 6.8.2. Every three months lubricate the brake lever pivots, the gears and chain with light oil and the brake arm bushes (not the brake blocks or disc pads) with a little grease.
- 6.8.3 Once a year, have your dealer re-grease the headset bearings, front wheel bearings and pedal bearings.



6.9 Recommended tools for proper maintenance:

Torque wrench with lb•in or N•m gradations 2, 4, 5, 6, 8 mm Allen wrenches

9, 10, 15 mm open-end wrenches 15 mm box end wrench

Socket wrench, 14, 15, and 19 mm socket T25 Torx wrench

No. 1 Phillips head screwdriver Bicycle tube patch kit, tire pump

7 Technical specifications & performance

Type	Wisper Works 905se range
Performance	(with 75kg 165lb rider)
Assisted range	8A up to 50km 14A up to 85km
Battery only	8Ah up to 38km 14Ah up to 50km
Maximum speed	25kph (15.5mph)
Weight with battery	Sport 23 / 24kg, City S 24 / 25kg
Maximum load	130kg (240kg)
Battery specifications	
Cell Type	Advanced Environmental Lithium Polymer with BMS
Capacity	8Ah or 14Ah
Rated voltage	37V
Main Controller specifications	
Low voltage safeguard	31.5V
Overload current safeguard	14A
Main hub motor specifications	
Motor type	Hi speed brushless
Rated power	Aus 200W / NZ Europe 250W / USA Canada 350W
Rated voltage	36V
Charger	Lithium 115 to 230V 36V fan cooled

8 Simple Trouble shooting

Problem	Possible reasons	Trouble shooting
Top speed too slow	<ol style="list-style-type: none"> 1. Low battery voltage 2. Handle bar control problem 3. Damage to motor driveline 	<ol style="list-style-type: none"> 1. Recharge battery fully 2. Call service 3. Call service
Power on but motor not working	<ol style="list-style-type: none"> 1. Battery not connected 2. battery fused 3. Motor connection damaged 4. Handle bar control problem 	<ol style="list-style-type: none"> 1. Re install battery 2. Replace fuse 3. Call service 4. Call service
Driving shorter distance per recharge	<ol style="list-style-type: none"> 1. Tyre pressure too low 2. Undercharge or charger fault 3. Battery capacity loss or damage 4. Hill climbing, frequent stops, strong head winds, over loading 	<ol style="list-style-type: none"> 1. Check pressures 2. Recharge completely or have charger inspected 3. Replace battery 4. Use power assist and try and avoid throttle only

Part 2 Controls and Equipment

In this section we will describe the functions and any specific maintenance needed on all the main controls and ancillary equipment.

9 Battery on off and battery lock

9.1 Your Wisper bike has one key. The key turns the battery on/off and locks the battery in the bike. Please keep a careful note of the key numbers as we cannot replace them without these numbers should they become mislaid.

9.2 The battery is connected to the electrical system of the bike automatically when you slide the battery into the frame. To turn on the bike's electrical system, turn the key in the battery clockwise, to turn off the power turn the key anti clockwise.

9.3 When the battery has been turned on the bike is now ready for use. The ON/OFF button on the handle bar isolates the power from the bike, when the bike is "on" you will see the battery power lights illuminate above the capacity indicator. When the ON/OFF button is pushed and the lights go out you have turned the bike "off". When the bike is "off" you will not get any assistance from

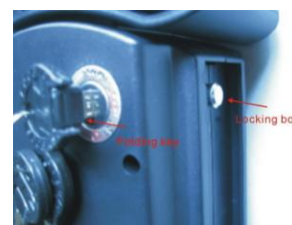



the battery and motor and the bike is effectively simply an unpowered push bike.

- 9.4 To lock the battery into the bike frame turn the key clockwise the locking bolt holds in the frame, if you want to turn the battery power on, turn clockwise again, if you want to unlock press the key in and turn the key anti clockwise fully while the key at lock position (Refer to the picture). Please read section 3 and 4 for battery care and advice on charging at the beginning of this manual.
- 9.5 The battery can be charged either on or off the bike.
- 9.6 To remove the battery turn off the power by turning the key to position "Unlocking", and remove the seat post and saddle. Using the handle on top of the battery lift out the battery.
- 9.7 To replace the battery reverse the procedure for removing it.

On the handle bars

10 The ON/OFF button

- 10.1 To turn the power on so the pedelec and throttle work simply press the ON/OFF button once, the lights will illuminate showing the power is on. When the ON/OFF button is pushed again and the capacity indicator lights go out you have turned the bike "off". When the bike is "off" you will not get any assistance from the battery and motor and the bike is effectively simply an unpowered push bike.



11 The LIGHT button

- 11.1 The LIGHT button can be found close to ON/OFF button. If you press it when the bike power is on, the LED headlight on the front fork will illuminate. Press it again to switch of the light. The power for the light comes from the bike battery. Due to a low power consumption use of the light will not reduce your range.



12 Pedelec mode and ASSIST mode

- 12.1 When you first ride your Wisper bike you will notice that after one turn of the pedals the motor will start working assisting you ride the bike by adding power to the back wheel. This is the standard or pedelec mode. To continue using the pedelec mode you must keep turning the pedals, if you stop pedaling the motor will stop and the bike will slow to a halt. If you start pedaling again after one turn the motor will start again.
- 12.2 You will find the ASSIST button on the panel on the handle bars marked with L.M.H (Low, Medium, High) with three corresponding LED's (small lights). When the button is pressed sequentially the LED shifts between L M and H. L means 40% of the maximum power in pedelec mode, M means 80%, and H means 100%.
- 12.3 High mode is generally used when you need the maximum amount of assistance from the motor. Low mode is used when you do not need the instant power of 80% or 100%. Low mode is used in high traffic situations or poor conditions such as ice and snow when 80% of full power immediately could be dangerous.

13 Throttle

- 13.1 The throttle can be used independently to the pedelec mode but the operation will vary depending on the country where the bike is supplied. Bikes are set up to be legal in the region in which they are supplied and will either provide full power (100%) or power up to 4 mph (6kph) (walkalong mode) independently of the pedelec.
- 13.2 The independent use of the throttle, when available, will enable you to use the throttle without pedaling.
- 13.3 The use of the throttle in pedelec mode is legal in most countries. Throttle in pedelec mode enables you to apply the power to the motor as long as you are pedaling the bike, if you stop pedaling the motor will stop too. If you have the pedelec mode set too low, you can increase the assistance from the motor from 40% to 100% of available power simply by turning the throttle towards you.

IMPORTANT Make sure your throttle and handlebar grips and the grip on the left are always intact and in good condition. Uncovered handlebar tubes can be very dangerous.

14 Brakes

14.1 Front: Disc Rear: V brake

14.2 The brakes on your Wisper bike are fitted with cut outs which are required by law. This means that when you pull on either the back or front brake lever the motor immediately stops working.

14.3 Regularly inspect brake pads for wear. Replace disc brake pads that are thinner than 1.0 mm.



A-Cable clamp bolt B-No contact
C-Pad fixing bolt D-Centering screw
E-Arm fixing bolt

V brake:

14.3.1. Use a 5mm Allen key to loosen bolt "A" to release the cable. Use a 5mm Allen key to loosen bolt "C" (right & left), then remove the spacers and washer

14.3.2. Install new brake pads, then with both pads pressed against the wheel rim, ensure that distance-B (in diagram) does not exceed 65mm. To decrease distance-B, exchange wide & narrow spacers on each brake pad. Before finally tightening brake pads, make sure they are aligned correctly on the rim, and there is a gap of 1mm between the top of the rim and the top of the pad. Hold each pad against the rim (one at a time) & tighten "C" bolt. Final tightening Torque: 6-8N.M

14.3.3. Refit the cable to bolt "A", slot cable guide pipe into holder and fit protector over guide pipe end. Adjust cable in bolt "A" bolt so that combined pad/rim clearance (the gap from left pad to left rim surface and from right pad to right rim surface) is 2mm, then tighten bolt "A". Final tightening torque: 6-8N.M.

Balance brake arms by turning screw "D". Apply the rear brake lever a few times while checking to see that tension is equal for both arms. Pad/rim contact should occur at the same time each side. Clearance should be 1mm each side. Do not set the tension too high.

14.3.4. Re adjust pads so they are properly aligned (see step 2), as tension adjustment may have altered original pad alignment.

Disc:

Mechanical disc brakes offer several advantages over traditional rim brakes better braking in wet, muddy or other adverse conditions, less braking power

fade over extended downhill braking and the ability to continue braking even if your rim becomes bent or distorted.

14.3.5. Adjust the pads and caliper

14.3.5.1. On the disc brake use a 5mm Allen wrench to adjust the stationary caliper adjusting bolt at the back (hub side) of the caliper. Adjust the bolt so that there is 0.3mm clearance between the stationary (hub side) pad and the rotor.

14.3.5.2. Adjust the cable adjuster bolt on the caliper so that there is 0.3mm clearance between the outside pad and the rotor.



14.3.6. Installing and removing pads.

Caution: The pads and rotor must be kept clean and free from oil or grease based contamination. If the pads become contaminated you must discard them and replace them with a new set. A contaminated disc should be cleaned with a proprietary brake cleaning solution.

14.3.6.1. Holding the pad end-tab, insert it into caliper slot with its metal backing towards the piston. Make sure the hole in the metal backing goes over the piston pins. When correctly inserted, the pad will be held in place magnetically, repeat the procedure for the other pad.



14.3.6.2. Pads can be removed by grasping the pad end-tab, lifting the pad clear of the piston pin and then manoeuvring it out of the rotor slot in the caliper body.



Note: Disc brake pads are held in the caliper magnetically. No tools are required to install or remove them. As the left and right pads are the same they maybe inserted on either the left or right of the caliper.

Warning: If you are unsure about any part of the installation process you should seek advice from Wisper service center or qualified mechanic.

15 Stem handle bar clamp

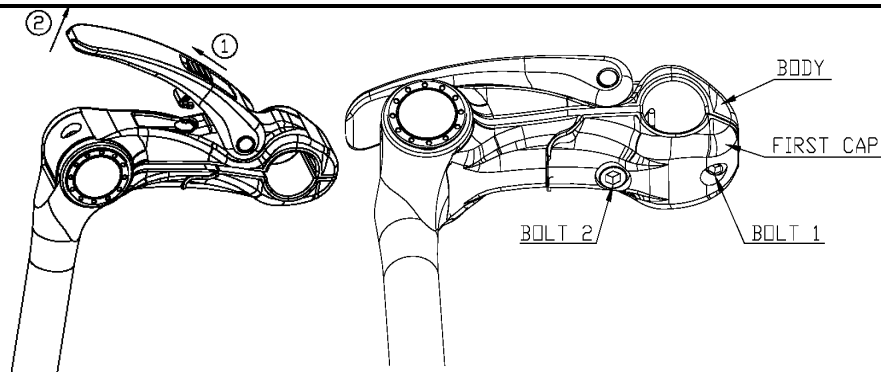

- 15.1 Your bike has been fitted with a quick release handlebar clamp that allows you to change the position of the bars quickly and easily to find the most comfortable riding position.
- 15.2 The stem and handle bars need to be fitted before you use the bike.
- 15.3 To fit, insert the stem into the front tube at least to the position of the “Minimum insertion” mark.
- 15.4 Tighten the quill bolt and fix stem.
- 14.5 Push in the direction of the arrow slide cap 1 and lift lever 2.
- 15.6 Adjust stem to preferred angle and lightly tighten BOLT 1 then turn BOLT 2

to a suitable position so that the slide cap 1 will fit when locked, then press down lever 2 to lock the handle bars in position.

- 15.7 Test the bars to make certain they are tight and do not rotate. If they are not tight enough, lift lever 2, adjust BOLT 2 again then press down lever 2. Repeat until the handle bars are tight and safe.

IMPORTANT when fitting always lock Bolt 1 first so the body and first cap touch then lock Bolt 2.

- 15.8 When adjusting stem angle, it is not necessary to adjust bolts.

16 The front connection box

- 16.1 The front connection box allows for the easy removal for repair or replacement of any of the electronic components on the handle bars. If opened ensure no wires are trapped between the two parts when reassembling and do not over tighten the 4 securing screws.



17 Quick release saddle height adjustment

- 17.1 Your Wisper bike has been fitted with a quick release saddle post collar to facilitate the movement of the saddle to remove the battery or to change the riding position.

- 17.2 It is important that the nut on the collar is tightened so the post will not move in the bike tube. Make this adjustment with the quick release lever in the open position.
- 17.3 Adjust the seat to the correct height and close the lever. When you sit on the saddle there should be no vertical movement at all in the saddle post. Never apply grease to the saddle post.

18 Saddle post suspension

- 18.1 For your comfort your bike has been fitted with saddle post suspension it has been set for a person weighing 75kg. If you are lighter than this you may not feel any benefit and if you are heavier you may feel the suspension bottoming out.
- 18.2 The suspension post can be adjusted by removing the whole post with saddle attached from the bike. On the bottom of the post you will find an Allen key adjuster. Simply turn it clockwise to tension the spring for heavier people and anticlockwise to release tension for lighter people.

IMPORTANT never raise the saddle post the point where the maximum marks on the saddle post are visible above the quick release collar and never grease the post.

19 Rims and spokes

- 19.1 It is essential to get your spokes checked and tightened after 300 miles. This is a free service provided by your supplier. If this service has not been undertaken at the correct time this may cause damage to the wheels and spokes that will not be covered under our guarantee.



20 Chain and drive wheel

- 20.1 The chain and drive wheel are made from rust proof materials.
- 20.2 Lightly oil with bicycle chain oil the chain at least every 3 months or more often in harsh conditions.
- 20.2 Because your bike has a rear derailleur the chain will be automatically adjusted.

21 Derailleur

- 21.1 Full details on how to adjust and maintain your derailleur can be found on our website www.wisperbikes.com Electric bikes, Manuals.

Warranty

Repair or replacement of components

IMPORTANT To validate this Warranty the retail customer must register the bike at www.wisperbikes/mywarranty within 14 days of purchase.

Only use this product in accordance with this user manual. We offer a limited warranty of on the following items.

1	The main frame	Six years
2	Gears, bearings, motor shell, hub motor, front forks	Two years
3	Handle bar controls, brakes (excluding brake shoes and pads)	One year
4	Controller and Charger	Two years
5	Battery casing, battery leak, battery capacity step-down more than 25%	Two year
6	Paintwork (excluding deliberate or accidental damage)	Two years
7	Front and rear axle, flywheel or chain wheel	One year
8	Electro plating, on wheel rims, rack and kickstand	Six months
9	Other cases that render the bike unsafe to use.	By negotiation

1. If the product has a quality fault within 15 days of delivery the part will be repaired or replaced or in exceptional circumstances we may replace the whole vehicle.
2. The period of assurance shall commence from the day delivery was made to the retail customer,



or from the day the retail customer collected the bike from the retailer.

3. To validate this Warranty the retail customer must register his / her bike at www.wisperbikes/mywarranty within 14 days of purchase.

Exceptions to Limited Warranties

1. Damage resulting from misuse, not maintaining the vehicle or not following the guidelines within this user guide
2. Accidental or deliberate damage
3. Damage due to private repair or alteration by user or unauthorised service centre.
4. Failure to produce invoice or proof of purchase.

5. Spare parts and components worn in normal use.
6. Failure to register your bike at www.wisperbikes/mywarranty within 14 days of purchase.

It is essential to get your spokes checked and tightened after 300 miles. This is a free service provided by your supplier. If this service has not been undertaken at the correct time this may cause damage to the wheels and spokes that will not covered under our guarantee.

Service through

Your retailer

or

Wisper Ltd

10 Oakenbrow

Sway

Hants

SO41 6DY

Tele: 01590 681553

Mobile: 07977 185830

douglas.lawson@wisperbikes.com

www.wisperbikes.com

Copyright January 2010 Wisper Ltd